

FL2000

FLOOR LEVEL PALLETIZER

The FL2000 floor level palletizer is flexible, energy efficient, loaded with safety features and EASY: easy to install, easy to operate, easy to maintain, easy to adjust and flexible for tomorrow's unknown packaging challenges. Requiring no modification, the FL2000 can handle a wide variety of package types including cases, trays, totes, film only and display packs from a variety of industries. The FL2000 palletizes 20 cases per minute or more, depending on case size and pallet pattern.



FEATURES

- Comprehensive Guard Package
- Category 3 Safety Electrical System
- Interlocked Access Doors to Load Build Area
- Full Height Light Curtains at Discharge
- Automatic Hoist Protection Pins
- Product Manager for Pattern Creation and Tuning
- Heavy Duty Sensor Mounts
- 4-Sided Pallet Stack Retention
- Stack Light / Beacon
- Smart Squeeze Technology for Misformed Layer Detection
- Low Pallet Detection
- Low Sheet Detection
- Heavy Duty Construction
- 80 Pitch Hoist Chain
- Infeed Tunnel Guard
- UL Approved or CSA Certified Control Panel
- Ethernet Enabled PLC with Distributed I/O
- Online parts ordering at www.palletizing.com
- 24-Hour parts and service hotline 1.800.628.4065

To view a video of the FL2000 in operation and for more information on Columbia's complete line of palletizers, please visit www.palletizing.com or call toll-free at 1.800.628.4065 / direct at 1.360.694.1501.

COMMON PALLETIZER LAYOUTS

- ① *Infeed*
- ② *Palletizer*
- ③ *Pallet Dispenser*
- ④ *Discharge*

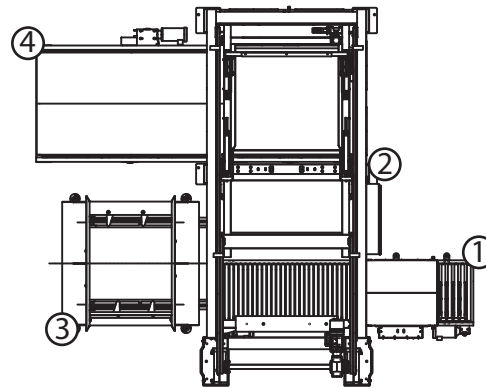
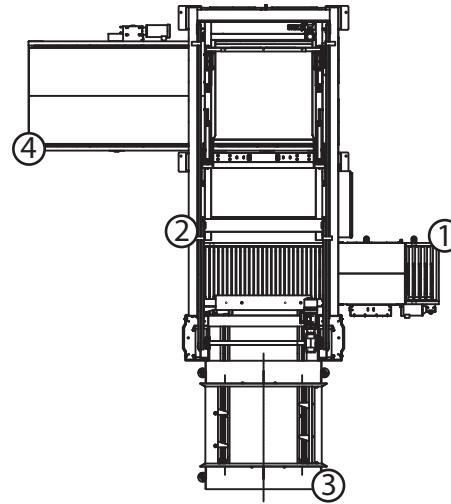
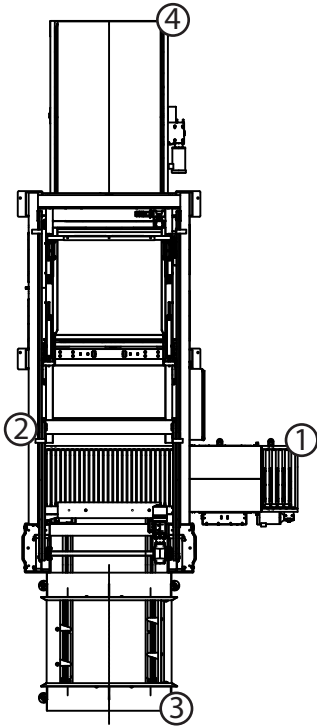

OPTIONS

- Wireless controls interface
- Labels-out stacking
- Speed enhancement upgrades
- FDA accepted stainless steel paint
- Upstream and downstream conveyor and interfacing
- Discharge conveyor
- Slip / Tie / Cap sheet dispenser
- Unitizing
- Turnkey system integration
- Soft product handling