

FL6200-SW

FLOOR LEVEL PALLETIZER

The FL6200-SW combines high-speed stretch wrap with a contemporary, modular and clean design palletizer that is extremely user friendly. The integrated stretch wrapper helps when load stability or when space constraints are an issue. The FL6200-SW can simultaneously stack and stretch wrap a wide variety of challenging package types including unwrapped trays, shrink pads, film-only bundles and more. With the incorporation of servo technology, high-speed turntable and high speed stretch wrapper speeds up to 100 cases per minute are achieved.



FEATURES

- Comprehensive Guard Package
- Category 3 Safety Electrical System
- Interlocked Access Doors to Load Build Area
- Full Height Light Curtains at Discharge
- Automatic Hoist Protection Pins
- Product Manager for Pattern Creation and Tuning
- Heavy Duty Sensor Mounts
- 4-Sided Pallet Stack Retention
- Stack Light / Beacon
- Smart Squeeze Technology for Misformed Layer Detection
- Low Pallet Detection
- Low Sheet Detection
- Heavy Duty Construction
- 80 Pitch Hoist Chain
- Infeed Tunnel Guard
- UL Approved or CSA Certified Control Panel
- Ethernet Enabled PLC with Distributed I/O
- Online parts ordering at www.palletizing.com
- 24-Hour parts and service hotline [1.800.628.4065](tel:1.800.628.4065)

To view a video of the FL6200-SW in operation and for more information on Columbia's complete line of palletizers, please visit www.palletizing.com or call toll-free at [1.800.628.4065](tel:1.800.628.4065) / direct at [1.360.694.1501](tel:1.360.694.1501).

COMMON PALLETIZER LAYOUTS

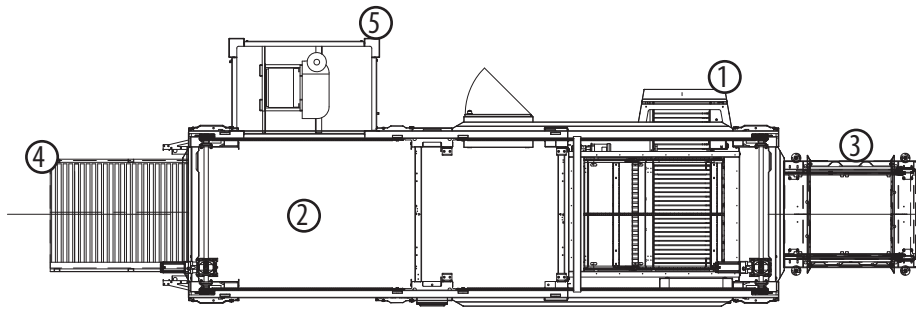

- ① **Infeed**
- ② **Palletizer**
- ③ **Pallet Dispenser**
- ④ **Discharge**
- ⑤ **Stretch Wrapper**
- ⑥ **Dual Infeed**

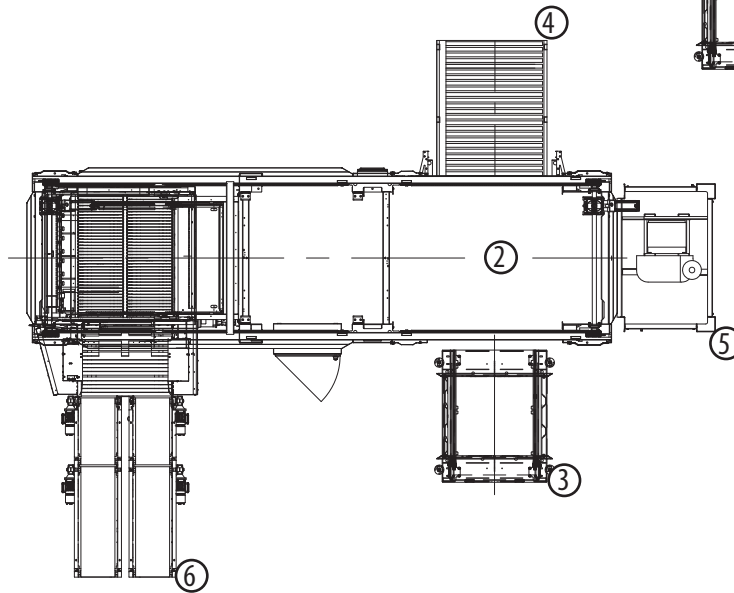
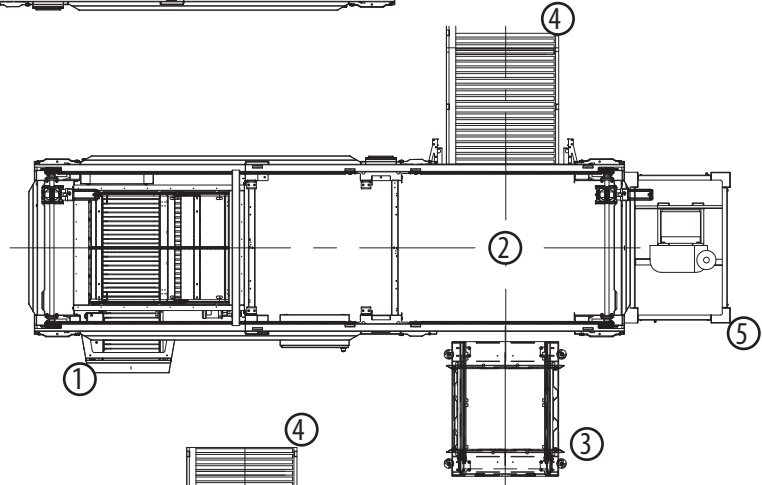

OPTIONS

- Wireless controls interface
- Labels-out stacking
- Speed enhancement upgrades
- FDA accepted stainless steel paint
- Upstream and downstream conveyor and interfacing
- Discharge conveyor
- Slip / Tie / Cap sheet dispenser
- Unitizing
- Turnkey system integration
- Soft product handling
- Dual infeed configuration