



FL1000

Floor Level Palletizer

The FL1000 floor level palletizer provides an optimal price and speed combination for low speed applications. Small enough to be moved through an 8' x 8' doorway, the FL1000's compact footprint utilizes less than 60 square feet of floor space. Requiring no modification, the FL1000 can handle a wide variety of package types, including cases, trays, totes, film only and display packs from a variety of industries. The FL1000 palletizes 10 cases per minute or more, depending on case size and pallet pattern.

Features

- » Comprehensive Guard Package
- » Category 3 Safety Electrical System
- » Interlocked Access Doors to Load Build Area
- » Full Height Light Curtains at Discharge
- » Automatic Hoist Protection Pins
- » Product Manager for Pattern Creation and Tuning
- » Heavy Duty Sensor Mounts
- » 4-Sided Pallet Stack Retention
- » Stack Light / Beacon
- » Smart Squeeze Technology for Misformed Layer Detection
- » Low Pallet Detection
- » Low Sheet Detection
- » Heavy Duty Construction
- » 80 Pitch Hoist Chain
- » Infeed Tunnel Guard
- » UL Approved or CSA Certified Control Panel
- » Ethernet Enabled PLC with Distributed I/O
- » Online parts ordering at www.palletizing.com
- » 24-Hour parts and service hotline 1.800.628.4065

Want to See More?

To view a video of the FL1000 in operation and for more information on Columbia's complete line of palletizers, please visit www.palletizing.com or call toll-free at 1.800.628.4065 / direct at 1.360.694.1501.



COMMON PALLETIZER LAYOUTS

- ① *Infeed*
- ② *Palletizer*
- ③ *Pallet Dispenser (optional)*
- ④ *Discharge Conveyor (optional)*

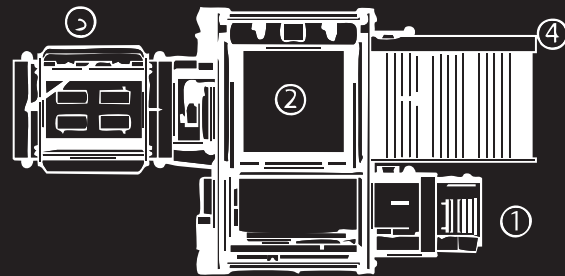
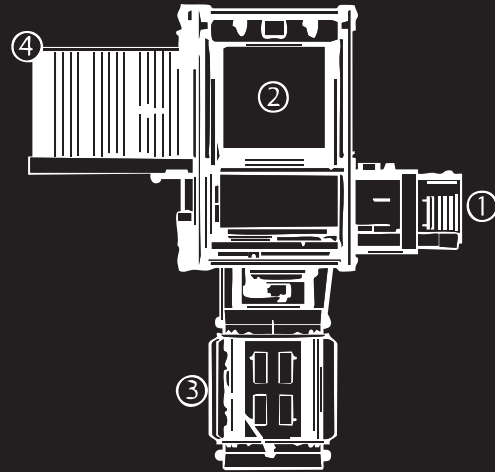
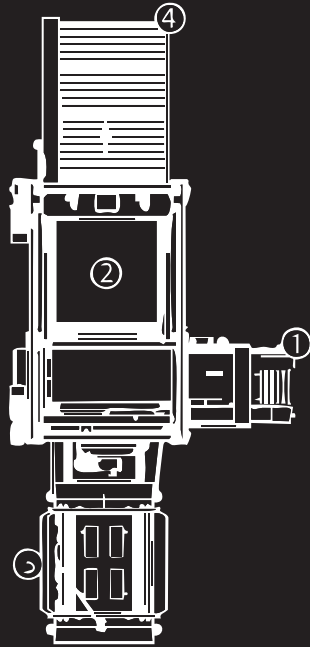

OPTIONS

- » Wireless controls interface
- » Labels-out stacking
- » Speed enhancement upgrades
- » FDA accepted stainless steel paint
- » Upstream and downstream conveyor and interfacing
- » Integrated stretch wrapper
- » Discharge conveyor
- » Slip / Tie / Cap sheet dispenser
- » Unitizing
- » Turnkey system integration
- » Soft product handling