



LTS-PD-IC-OC

Load Transfer Solutions

Load Transfer Stations are capable of transferring products that are packaged in cases, barrels, drums, bags and pails from one pallet to another including Plastic, Chep and GMA pallets in both receiving and shipping applications. Make your next load transfer an easy one with the LTS-PD-IC-OC from Columbia Machine, Inc.

Features

- » Automatic pallet upstack holds up to 12 pallets
- » Hydraulically actuated
- » Heavy-duty construction
- » Easy to operate
- » 5 HP integral hydraulic power unit
- » Weighs 15,000 lbs.
- » 4,000 lbs. load capacity
- » 5+ Emergency stops
- » Low maintenance
- » Allen Bradley PLC controls
- » 230, 460 or 575 VAC power supply
- » 24 VDC controls
- » UL / CSA rated control panel
- » Machine mounted guarding
- » Panelview Plus touchscreen HMI
- » Automatically dispenses "go to" pallet

Want to See More?

To view a video of the LTS-PD-IC-OC in operation and for more information on Columbia's complete line of palletizers, please visit www.loadtransfer.net or call toll-free at 1.800.628.4065 / direct at 1.360.694.1501.



LOAD TRANSFER SOLUTIONS

The Fully Automatic LTS System combines a pallet stacker, pallet dispenser, infeed conveyor and a powered outfeed cart. Fully Automated LTS units receive loads from a conveyor, transfers the load from one load base to another, stacks the "go from" pallet and automatically discharges the transferred load onto the outfeed cart. Transferred loads can then be automatically stored in a high rise ASRS system or picked up downstream by a lift truck or go to another operation.

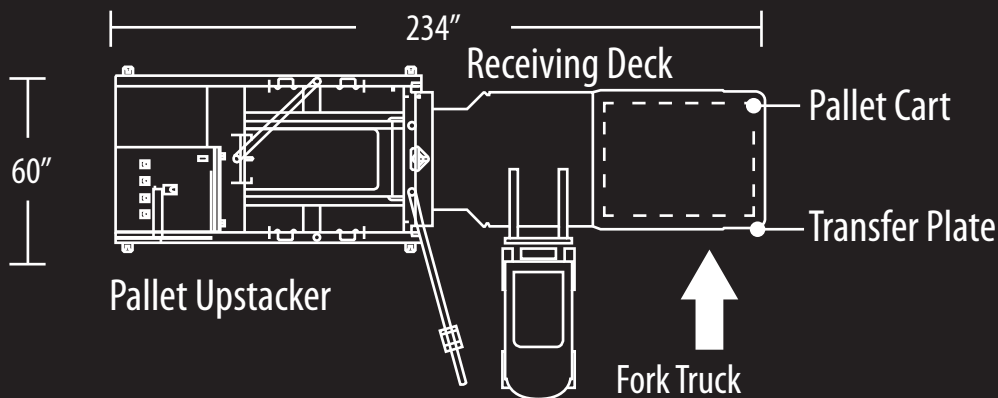

OPTIONS

- » Cold Climate Package: heaters for oil tank and control panel
- » Receiving deck shim kit
- » Slip sheet dispenser
- » Stainless steel paint wash down applications
- » Automatic pallet height adjustment
- » Automatic load placement adjustment: inset, flush, overhang

BENEFITS

- » Eliminate injury to warehouse personnel
- » Streamline plant and warehouse operations
- » Less wear and tear of lift trucks
- » Improve plant process cleanliness
- » Reduce shipping costs
- » Easy-to-operate (ETO)