

## FL6200-SW

### Floor Level Palletizer

The FL6200-SW combines high-speed stretch wrap with a contemporary, modular and clean design palletizer that is extremely user friendly. The integrated stretch wrapper helps when load stability or when space constraints are an issue. The FL6200-SW can simultaneously stack and stretch wrap a wide variety of challenging package types including unwrapped trays, shrink pads, film-only bundles and more. With the incorporation of servo technology, high-speed turntable and high speed stretch wrapper speeds up to 100 cases per minute are achieved.

### Features

- » Comprehensive Guard Package
- » Category 3 Safety Electrical System
- » Interlocked Access Doors to Load Build Area
- » Full Height Light Curtains at Discharge
- » Automatic Hoist Protection Pins
- » Product Manager for Pattern Creation and Tuning
- » Heavy Duty Sensor Mounts
- » 4-Sided Pallet Stack Retention
- » Stack Light / Beacon
- » Smart Squeeze Technology for Misformed Layer Detection
- » Low Pallet Detection
- » Low Sheet Detection
- » Heavy Duty Construction
- » 80 Pitch Hoist Chain
- » Infeed Tunnel Guard
- » UL Approved or CSA Certified Control Panel
- » Ethernet Enabled PLC with Distributed I/O
- » Online parts ordering at [www.palletizing.com](http://www.palletizing.com)
- » 24-Hour parts and service hotline 1.800.628.4065

## Want to See More?

To view a video of the FL6200-SW in operation and for more information on Columbia's complete line of palletizers, please visit [www.palletizing.com](http://www.palletizing.com) or call toll-free at 1.800.628.4065 / direct at 1.360.694.1501.



# COMMON PALLETIZER LAYOUTS

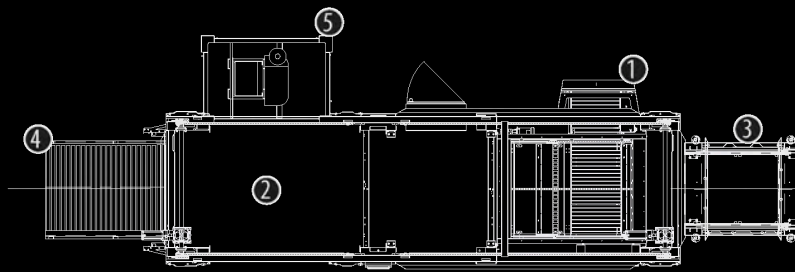

- ① Infeed
- ② Palletizer
- ③ Pallet Dispenser
- ④ Discharge
- ⑤ Stretch Wrapper
- ⑥ Dual Infeed

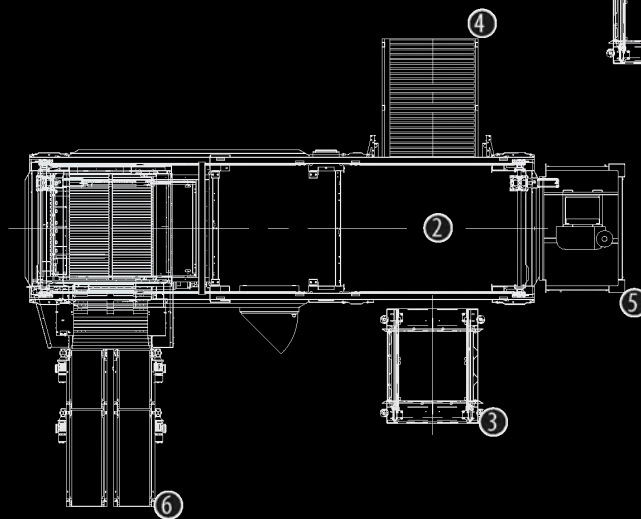
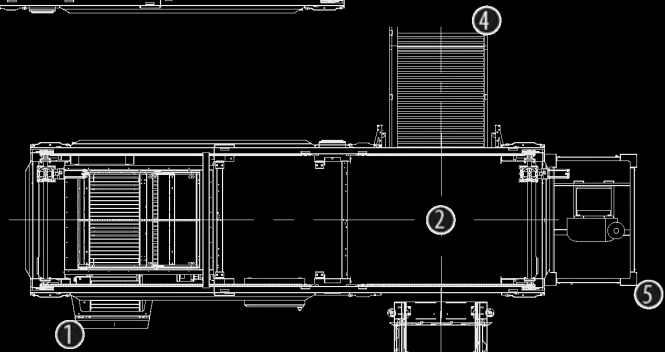

## OPTIONS

- » Wireless controls interface
- » Labels-out stacking
- » Speed enhancement upgrades
- » FDA accepted stainless steel paint
- » Upstream and downstream conveyor and interfacing
- » Dual infeed configuration
- » Discharge conveyor
- » Slip / Tie / Cap sheet dispenser
- » Unitizing
- » Turnkey system integration
- » Soft product handling