



## LTS-PD

### Load Transfer Solutions

Load Transfer Stations are capable of transferring products that are packaged in cases, barrels, drums, bags and pails from one pallet to another including Plastic, Chep and GMA pallets in both receiving and shipping applications. Make your next load transfer an easy one with the LTS-PD from Columbia Machine, Inc.

### Features

- » Automatic pallet upstack holds up to 20 pallets
- » Hydraulically actuated
- » Heavy-duty construction
- » Easy to operate
- » 5 HP integral hydraulic power unit
- » Weighs 10,000 lbs.
- » 4,000 lbs. load capacity
- » 3 Emergency stops
- » Low maintenance
- » Allen Bradley PLC controls
- » 230, 460 or 575 VAC power supply
- » 24 VDC controls
- » UL / CSA rated control panel
- » Machine mounted guarding
- » Overhead pivot pole cord switch
- » Automatically dispenses "go to" pallet



## Want to See More?

To view a video of the LTS-PD in operation and for more information on Columbia's complete line of palletizers, please visit [www.loadtransfer.net](http://www.loadtransfer.net) or call toll-free at 1.800.628.4065 / direct at 1.360.694.1501.

## LOAD TRANSFER SOLUTIONS

The Load Transfer Station with Pallet Dispenser (LTS-PD) is made up of a standard LTS, pallet cart and side load pallet dispenser. The forklift driver loads a stack of pallets into the pallet dispenser. The pallet dispenser automatically places the “go to” pallet onto the pallet cart. Then the forklift driver places the load to be transferred onto the receiving deck and activates the unit by pulling the cord, allowing the cycle to complete in less than 60 seconds.

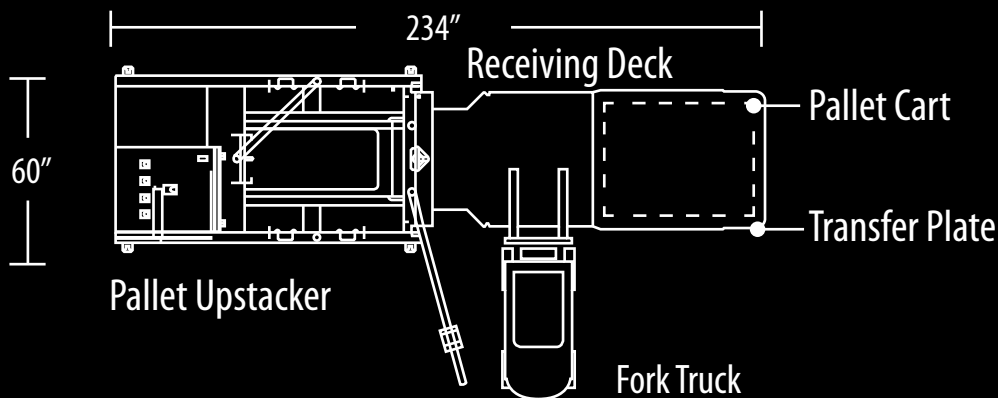

### OPTIONS

- » Cold Climate Package: heaters for oil tank and control panel
- » Receiving deck shim kit
- » Pallet cart shim kit
- » Stainless steel paint wash down applications
- » Automatic pallet height adjustment
- » Automatic load placement adjustment: inset, flush, overhand

### BENEFITS

- » Eliminate injury to warehouse personnel
- » Streamline plant and warehouse operations
- » Less wear and tear of lift trucks
- » Improve plant process cleanliness
- » Reduce shipping costs
- » Easy-to-operate (ETO)